



Customization of Footing Templates and Custom Abutments

Steve Willoughby
Senior Application Engineer, Bridges and Tunnels

OBM Pier Column Definition

- Variable: Multiple cross sections, several fixed length, one adjustable length

Software interface for defining a variable pier column. The window title is "Column 1" and includes an "Add Column +" button. The "Type" is set to "Variable". The configuration table is as follows:

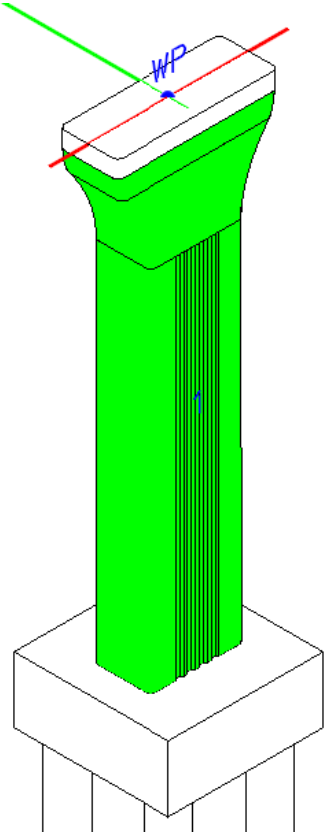

Variation	...
Length (unadjusted) (m)	12.00000
Auto Spacing	On



OBM Variable Column Definition

- For each section :
- Height
- Shape
- Start Dimension
- End Dimension
- Variation Type
- Adjustable Height (Yes-No)

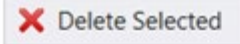
- Hint: Definition starts at the top of the column

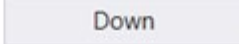
Sections						
						
	Section Height (m)	Shape	Start Dimensions (mm) (W, L, X, Y)	End Dimensions (mm) (W, L, X, Y)	Variation	Adjustable Height
>	0.55000	Rect-Fillet	4165.60000, 1524.00000, 152.40000	3937.00000, 1524.00000, 152.40000	Parabolic Start	<input type="checkbox"/>
	1.90000	Rect-Fillet	3937.00000, 1524.00000, 152.40000	2438.40000, 1524.00000, 152.40000	Parabolic End	<input type="checkbox"/>
	9.55000	Template			Linear	<input checked="" type="checkbox"/>

OBM Variable Column Definition

- Column Section Height:
 - Fixed section for all except one which adjustable height
 - The section can have different dimensions at start and end
 - If dimensions are different, the variation type can be chosen among: 
 - One and only shape per section
 - Shapes among:

Shape
Rect-Fillet ▾
Circular
Rectangle
Rect-Bevel
Rect-Fillet
Template

Linear
Linear With Slope
Parabolic Start
Parabolic End
Circular Start
Circular End

Adjustable Height
<input checked="" type="checkbox"/>

Start Dimensions (mm) (W, L, X, Y)	End Dimensions (mm) (W, L, X, Y)
4165.60000, 1524.00000, 152.40000	3937.00000, 1524.00000, 152.40000

OBM Variable Column Definition

- Template:
 - Pick a template from library stored in Templates.xml
 - The template can be controlled by variables

Variables				0.00 - 9.55000 Florida\Base Rotation By Angle* Default = 0°			
Variable	Active	Default	Errors				
Rotation By Angle*	<input checked="" type="checkbox"/>	0°					
Rotation By Slope*	<input type="checkbox"/>	0.00000					

Relative Location	Height	Start Value	End Value	Transition	
<input type="checkbox"/> 0.00000	9.55000	5°	10	Linear	

Add Section From Head m

OBM Custom Footing

- Template shape:
 - In utilities, open Footing library
 - We access a usual template editor

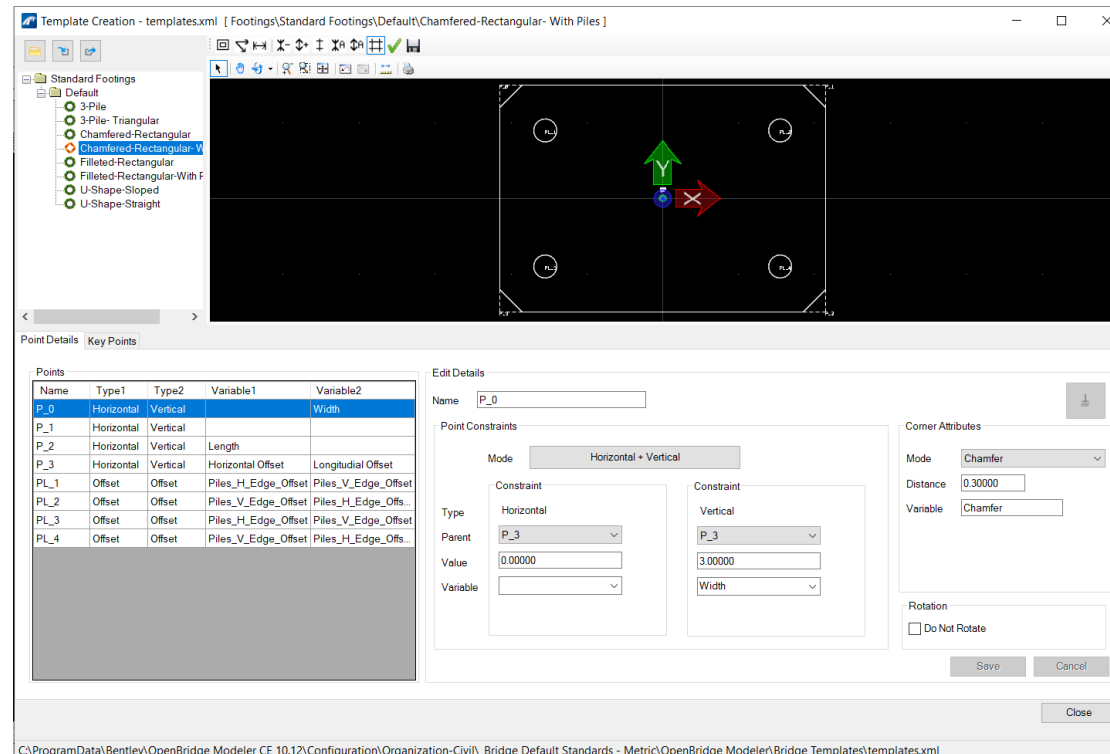
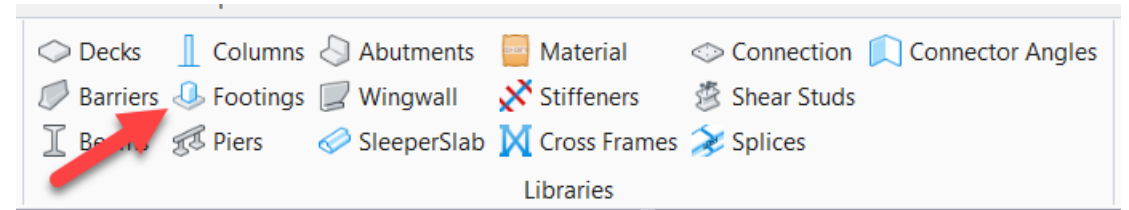

OBM Custom Footing

- Add a new template by drawing exterior definition of the footing
- Add Pile Locations by adding Circles



A screenshot of a software dialog box with a title bar containing a window icon, a minus sign, a maximize button, and a close button. The dialog has two text input fields: the first is labeled "Name" and contains the text "Hexagon"; the second is labeled "Description" and contains the text "6 sided footing". At the bottom right of the dialog are two buttons: "OK" and "Cancel".

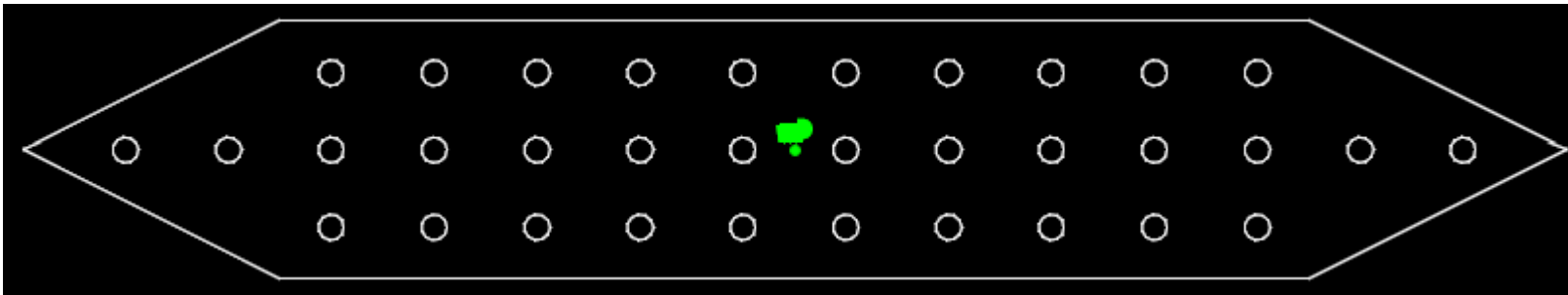

OBM Custom Footing

- Tag circles representing Pile locations

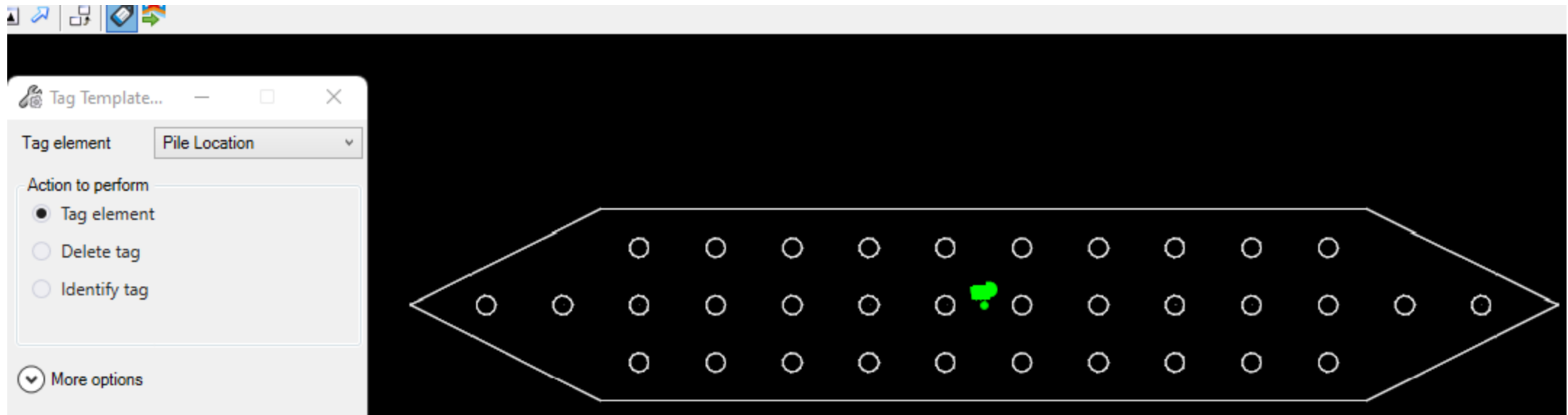

OBM Custom Footing

- Save the template
- Edit constraints and variables

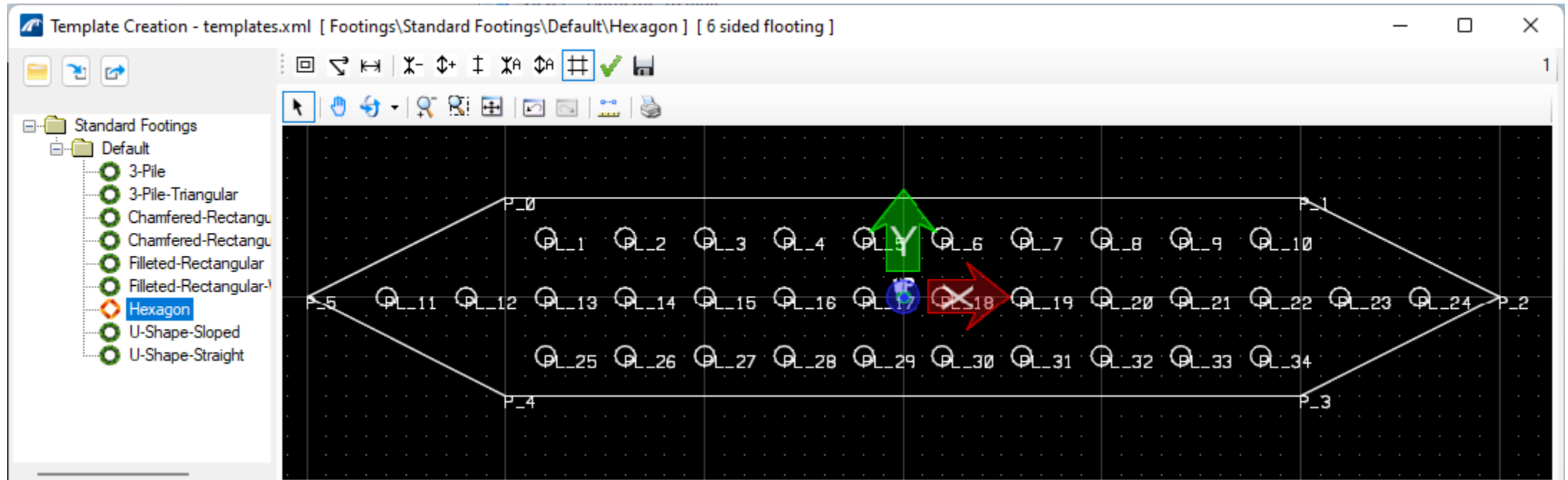

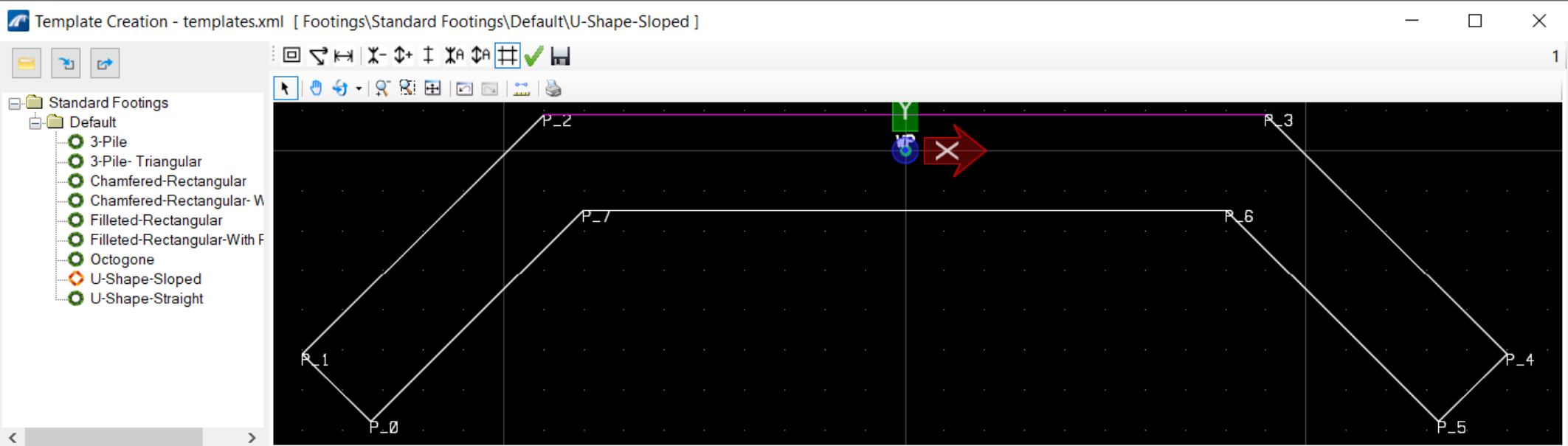

Point Details Key Points

Points

Name	Type1	Type2	Variable1	Variable2
P_0	Angle	Offset		Left_WingWall_W...
P_1	Angle	Offset	Left_WingWall_Angle	Left_WingWall_Of...
P_2	Horizontal	Vertical	Horizontal_Offset	Vertical_Offset
P_3	Horizontal	Vertical	Length	
P_4	Angle	Offset	Right_WingWall_Angle	Right_WingWall_...
P_5	Angle	Offset		Right_WingWall_...
P_6	Offset	Offset	Width	Right_WingWall_...
P_7	Offset	Offset	Left_WingWall_Width	Width

Edit Details

Name

Point Constraints

Mode **Angle + Offset**

Type	Parent	Value	Variable	Ref
Angle	P_2	45°	Left_WingWall_Angle	P_2 To P_3
Offset	P_2 → P_3	6.00000	Left_WingWall_Offset	

Corner Attributes

Mode **None**

Rotation

Do Not Rotate

Save Cancel

Close

OBM Custom Footing

- In the Pier or Abutment definition menu, choose Custom footing
- Modify Footing parameters
 - Height
 - Rotation Angle
 - Transverse and Longitudinal Offsets
- Adjust the Pile parameters
 - Pile Shape and Dimensions
 - Embed Length
 - Batter and Length of the Pile

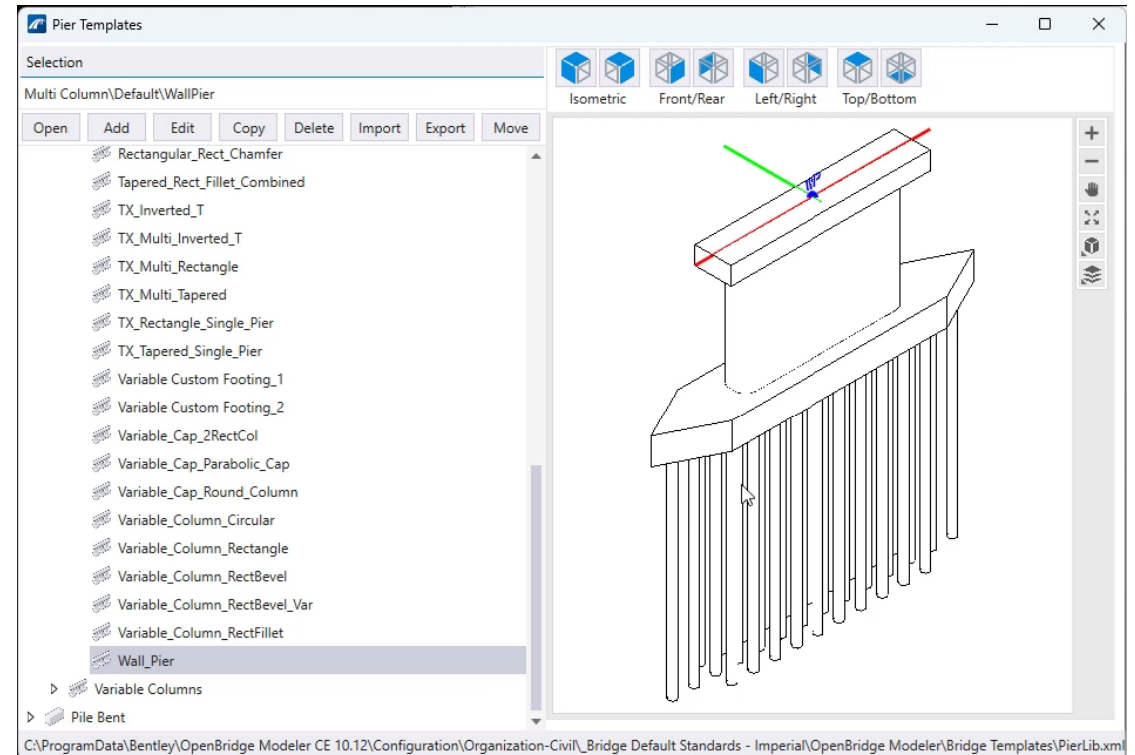

Limitations

- Limited transfer to LBS/LBC assuming bounding box
- No transfer to RM at this time
- No transfer via dgn file. Need to Import/Export Template

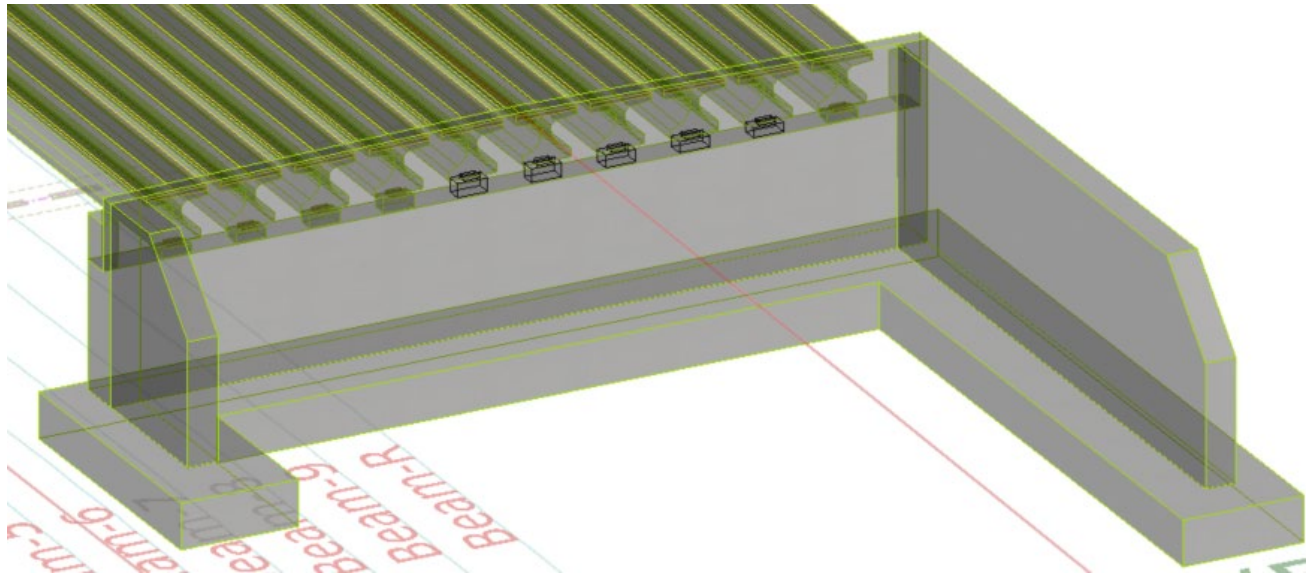
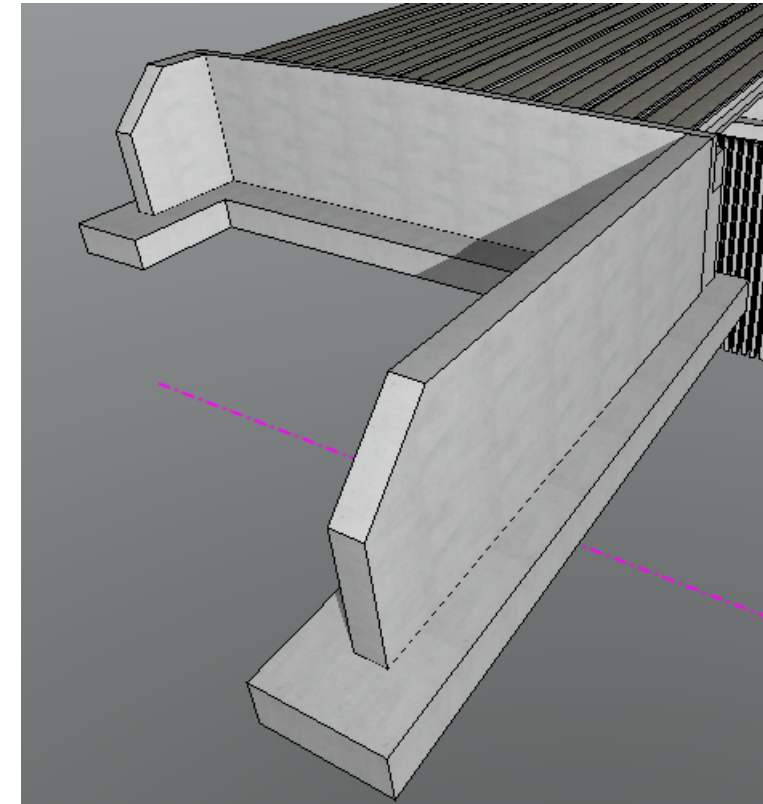
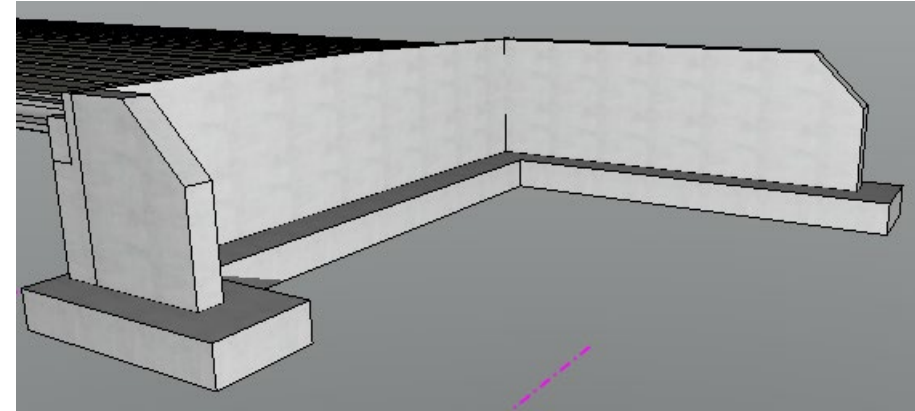

LEAP Bridge Concrete LEAP Bridge Steel RM Bridge ProStructures

Interoperability Import/Export

Decks Columns Abutments Material Connection Connector Angles

Barriers Footings Wingwall Stiffeners Shear Studs

Beams Piers SleeperSlab Cross Frames Splices

Libraries

Parametric Cell GC AccuDraw ACS iTwin Design Review Item Types Reports

View 1 - Top, Default

View 2 - Isometric, Default